

# Microcystins – potent xenobiotics

Maja Ilić<sup>1</sup>, Zorica Svirčev<sup>2</sup>, Vladimir Baltić<sup>1</sup>

## SUMMARY

Having in mind that exposure to low levels of microcystin in drinking water represents the health risk for people, microcystins can be observed as potent xenobiotics. The consequences of exposure to natural products of the blue-green algae, the microcystins, are numerous. Among other things, there is a possibility of development of malignant disease of colon and liver. The occurrence of the tumor is, on one side, enabled by the active transportation of microcystin for achievement of high concentration intracellularly and, on the other side, by high affinity of microcystins for serine/threonine phosphatase PP1 and PP2A after which follows their inactivation. The system, which is responsible for the active transportation of microcystin, is a family of polypeptides for transportation of organic anions (OATP). Isoforms of these carriers are distributed in one tissue, like OATP1B1 and OATP1B3, which are specific for liver or many tissues, OATP1A2 carrier, present in the liver, kidney, brain and the small intestine. The consequences of high concentration of microcystin intracellularly, binding and the inhibitions of protein phosphatase, are numerous. For the occurrence of a tumor, the changes in the nucleus are important, which are related to the gene expression changes, changes in the system for damaged DNA repair and the changes in mitosis. Mediators of these changes have their role in protein activity regulation, signal transmission in the cell, damaged DNA repair, performance of the cell cycle, apoptosis, tumor suppression, cell proliferation and differentiation. Phosphatase inhibition is observed as the strategy of development of a new group of anticancer agents. As phosphatase inhibitors, microcystins and analogs are applied, possibly having the potential to express the difference in toxicity mechanism and detoxification mechanism between the healthy and the tumor cell of liver. High expression of OATP1B1 and OATP1B3 microcystin transporters in hepatocellular carcinoma would confirm selective impact of phosphatase inhibitors to the tumor cell.

**Key words:** Microcystins; Xenobiotics; Antineoplastic Agents; Organic Anion Transporters; Protein Phosphatase 1; Protein Phosphatase 2; Neoplasms

## INTRODUCTION

### MICROCYSTINS, BETWEEN XENOBIOTICS AND SELECTIVE ANTICANCER AGENTS

Microcystins, natural products of blue-green algae „blooms“, are today considered as significant pollutants of the surface waters. As the water factories are partly supplied from such sources and cannot completely remove the microcystins, there is a question regarding the influence of such present microcystins to the health of population after a long-term, chronic exposure to low doses in the drinking water. Thus, the World Health Organization introduced the level of intake of microcystins in drinking water, which can be tolerated during one day.

Epidemiological studies show that the exposure to microcystins can be a risk factor for occurrence of the primary liver carcinoma, even being the only risk factor. There is a question whether the presence of any other risk factor such as HBV, HCV, aflatoxin or alcohol is also needed. The consequences of exposure to microcystins in drinking water have, however, extended further than liver, to colon, brain, heart, kidney, reproductive organs. There is evidence that microcystins act as tumor promoters, initiators and genotoxic carcinogens (1-3).

What is the toxicity of microcystins in a human body or, more precisely, which molecular mechanisms enable the expression of toxic effect? What are the consequences of human chronic exposure to microcystins? Considering that numerous substances with healing properties were extracted from nature, is

it possible that the previously stated microcystin toxicity mechanisms can be used in therapeutic purposes on the basis of the differences between the malignant and the healthy cell? Is this going to be another attempt to find the therapeutic strategy, which will show selectivity? For several years now, various studies have been confirming these facts.

### MICROCYSTINS – THE NATURE OF THE MOLECULE

One of the ways of microcystin intake into the human organism is through drinking water. The molecule itself is of a relatively complex structure, a cyclic heptapeptide, with about 80 known variants. In the microcystin molecule, there are two variable amino acids and in the most frequent forms of this molecule, these two amino acids are the combination of leucine, arginine and tyrosine. In microcystin LR, these two variable amino acids are leucine and arginine. Variations in the molecule structure are the prerequisite of possible molecule synthesis in therapeutic purposes (Figure 1) (1, 4, 5). Molecular weight of microcystin is between 900-1100 daltons. These are two significant reasons why a passive diffusion of microcystin molecules is impossible inside the cell, so the influx occurs through active transport. The active transportation is a widely present way of transportation of numerous endogenous (nutrients, metabolites) and exogenous (medicines, chemicals) substances, which represent the substrate for protein carrier-transporters. The transporter, specific for microcystins belongs to the polypeptide family for transportation of organic anions – OATP (Organic Anion Transporting Polypeptide). OATP is, however, multispecific so its isoforms, OATP1A2,

Arch Oncol 2011;19(3-4):67-72.

UDC: 616.348-006:616.36-006:576.385  
DOI: 10.2298/AOO11040671

<sup>1</sup>Oncology Institute of Vojvodina, Sremska Kamenica, Serbia;  
<sup>2</sup>Department of Biology and Ecology, Faculty of Sciences, Novi Sad, Serbia

Correspondence to:  
Maja Ilić, Oncology Institute of Vojvodina, Institutski put 4, 21204 Sremska Kamenica, Serbia

majai@nebee.net

Received: 14.09.2011  
Provisionally accepted: 20.09.2011  
Accepted: 26.09.2011

© 2011, Oncology Institute of Vojvodina, Sremska Kamenica

OATP1B1 and OATP1B3, beside other substances, perform the transport of one of microcystin variants (microcystin with leucine and arginine amino acids in the structure of MC-LR). What the distribution of microcystin will be in different organs will depend on OATP carrier expression in these tissues and on blood perfusion through them (4, 6).

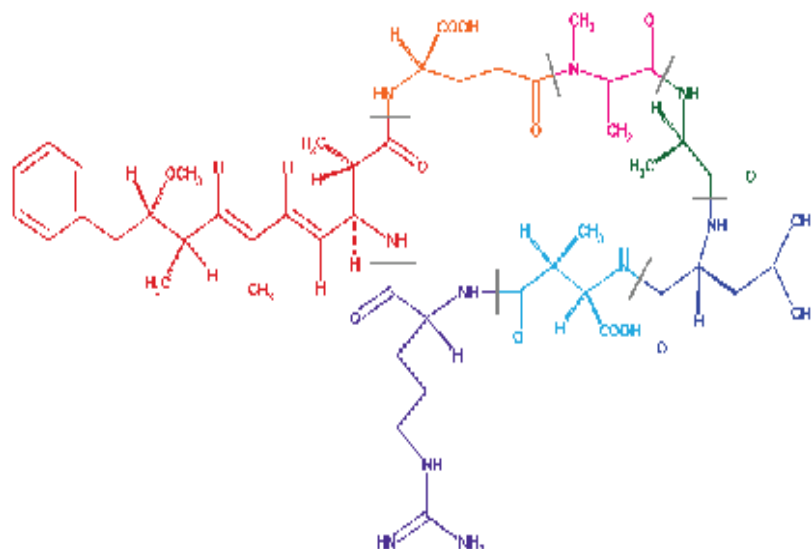

Figure 1. Microcystin LR molecule (MC-LR)

### OATP – PEPTIDE FAMILY FOR TRANSPORTATION OF ORGANIC ANIONS OATP STRUCTURE

OATP is of a protein nature. It consists of 12 helices – transmembrane domains, integrated in a double-layered biomembrane with N (amino) and C (carboxy) terminal residues oriented towards cytoplasm. The helices 1, 2, 4, 5 with the amino residue and 7, 8, 10, 11 with the carboxy residue are oriented towards the central pore, while the helices 3, 6, 9, 12 are oriented inside the double-layered membrane. Inside the transporter, there is a central pore whose electrostatic potential is positive. This facilitates binding and transportation of negatively electrified components, which is in accordance with the anionic nature of most of the substrates transported by OATP. For positive potential of the pore, the amino acidic residues arginine, histidine

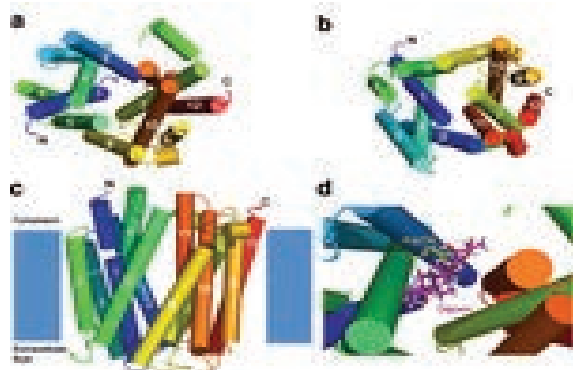

Figure 2. Structural model of OATP1B3 from: a) intracellular side, b) extracellular side, c) laterally. The helices were shown as cylinders in rainbow colors. Figure c) Approximate presentation of a double-layered membrane and N and C terminal residues. Figure d) the presentation of an OATP1B3 carrier with the digoxin molecule in the central pore from the intracellular side (7).

and lysine are significant. However, only for arginine 181 and histidine 579, it is known that they are electrified and oriented towards the pore, and as such, they are unique, the first one for the OATP1 family, the second one for the OATP2 family, as the parts for binding and transportation of the substrates. A major characteristic of all OATPs is a large extracellular domain between the transmembrane domains 9 and 10 (Figure 2) (6- 8).

### OATP DISTRIBUTION IN HEALTHY TISSUE AND ITS LOCALIZATION IN THE CELL

OATP isoforms distribution varies from the presence in only one tissue to the presence in almost all human tissues. OATP subfamilies responsible for transportation of microcystin LR, OATP1B1 and OATP1B3 are almost entirely expressed in liver and only very mildly in other tissues, while OATP1A2 carrier is expressed in liver, kidney, brain and small intestine. When observed in relation to the cell, OATP1A2 is localized apically in cholangiocyte, small intestine villus enterocyte and in kidney distal tubule, while OATP1B1 and OATP1B3 are almost entirely specific for liver and are located basolaterally in hepatocytes (Table 1) (4, 6, 9).

Table 1. Localization of an organic anionic transportation carrier (OATP) in a cell

TRANSPORTER	ORGAN	CELL	LOCALIZATION
OATP1A2	LIVER	CHOLANGIOCYTE	APICAL
OATP1A2	SMALL INTESTINE	VILLUS ENTEROCYTES	APICAL
OATP1A2	KIDNEY	DISTAL TUBULE	APICAL
OATP1A2	BRAIN	CAPILLARY ENDOTHELIAL CELLS	UNKNOWN
OATP1B1	LIVER	HEPATOCYTE	BASOLATERAL
OATP1B3	LIVER	HEPATOCYTE	BASOLATERAL

### OATP FUNCTION IN TRANSMISSION OF SUBSTRATES

OATP is primarily the transporter of organic anions towards the cell interior. Active transportation is dependant on pH, electroneutral and two-way, i.e. the transport of organic anions inside the cell is performed in replacement for bicarbonate, glutathione or glutathione-S-conjugate (Table 2) (6, 10).

Table 2. Substrates for OATP 1A2, 1B1 and 1B3 (6)

TRANSPORTER	SUBSTRATE
OATP1A2	Microcystin-LR, methotrexate, estron-3-sulfate, thyroxine, triiodothyronine, levofloxacin, taurocholate, cholic acid, glycocholate, rosuvastatin, etc.
OATP1B1	Microcystin-LR, irinotecan, bilirubine and conjugates, cholic acid, taurocholate, glycocholate, estron-3-sulfate, dehydroepiandrosterone sulfate, estradiol-17 $\beta$ -glukuronid, thyroxine, triiodothyronine, pravastatin, fluvastatin, valsartan, troglitazone, etc.
OATP1B3	Microcystin-LR, irinotecan, paclitaxel, docetaxel, bilirubine conjugates, digoxin, valsartan, fexofenadine, thyroxin, rosuvastatin, estradiol-17 $\beta$ -glukuronid, etc.

## MICROCYSTIN TOXICITY MECHANISMS

The most significant mechanism of microcystin toxicity is inhibition of serine/threonine family, protein phosphatases PP1 and PP2A. Two groups of enzymes are responsible for the line of changes, which lead to signal transmission in the cell, which is, among some other things, related to the cell cycle and the cell death. Kinases catalyze protein phosphorylation, while phosphatase removes organic phosphate from the active spot of a regulatory molecule, which generally represents the end of the signal transmission (4, 5, 11).

Interaction of MC-LR with PP1 and PP2A is a two-degree process in which MC-LR binds for the enzyme, forms covalent bonds during the prolonged reaction time and blocks the active spot of the enzyme, thus inactivating it (4).

What is crucial for development of primary carcinoma of liver after acute or chronic exposure to MC-LR, is inhibition of PP1 and PP2A and/or mutation of genes responsible for cell cycle. For MC-LR, it is confirmed that it causes initiation and promotion, and after multiple mutations, the hepatocyte transformation and proliferation occurs (Figure 3) (1).

Initiation is the first step in carcinoma development, and the initial event is the reaction of chemical carcinogenic or a part of its molecule and nucleotide in the DNA molecule. Promotion implies acceleration of uncontrolled division of initiated cells, which increases the population of initiated cells and reduces the time from initiation to malignant transformation. This is followed by the process of malignant conversion or transformation of initiated cells with defined mutations inside the cell with complete phenotype of a malignant cell. During tumor progression, malignant cells acquire characteristics that are more aggressive (12).

Microcystins as potential inhibitors of phosphatases PP1 and PP2A indirectly affect the performance of the cell cycle and apoptosis or programmed cell death. Inhibition of PP2A and PP1 indirectly affects the genes responsible for the cell cycle and tumor suppressor p53, which through p21, cyclin and cyclin-dependant kinases stops the cell in G0-G1 and G2-M phases. If the occurred damage at the level of a DNA molecule at the moment of stopping of the cell cycle is not repaired, the cell undergoes apoptosis and further proliferation is enabled (1, 13).

MC-LR encourages the occurrence of free oxygen radicals, damaging of the cytoskeleton, release of cyt-c and Ca(II), which, as a consequence has activation of caspases and apoptosis. Apoptosis is the consequence of exposure to low doses of MC-LR through Bid-Bax-Bcl2 complex, then it is the consequence of MC-LR effect on ceramide because the mitochondrial cyt-c is induced. Ceramide controls the activity of PP2A, DAG, PKC, MAPK kinase molecules, responsible for transmission of proapoptotic or antiapoptotic signals, which consequently leads to proliferation or apoptosis. Ceramide can stimulate PP2A and inhibit DAG and PKC. Low, but also high doses at chronic, i.e. acute exposure to MC-LR activate the signaling pathway Raf-MEK-ERK, where, at the acute exposure, free oxygen radicals are formed, which may activate JNK kinase, which activates proliferation and inactivates apoptosis. Entire mechanism of the acute, chronic microcystin toxicity, as well as tumor initiation and promotion includes numerous factors with the end result of a cell survival or a cell death. The cell survival with the formed mutation leads to occurrence of a tumor (1, 12).

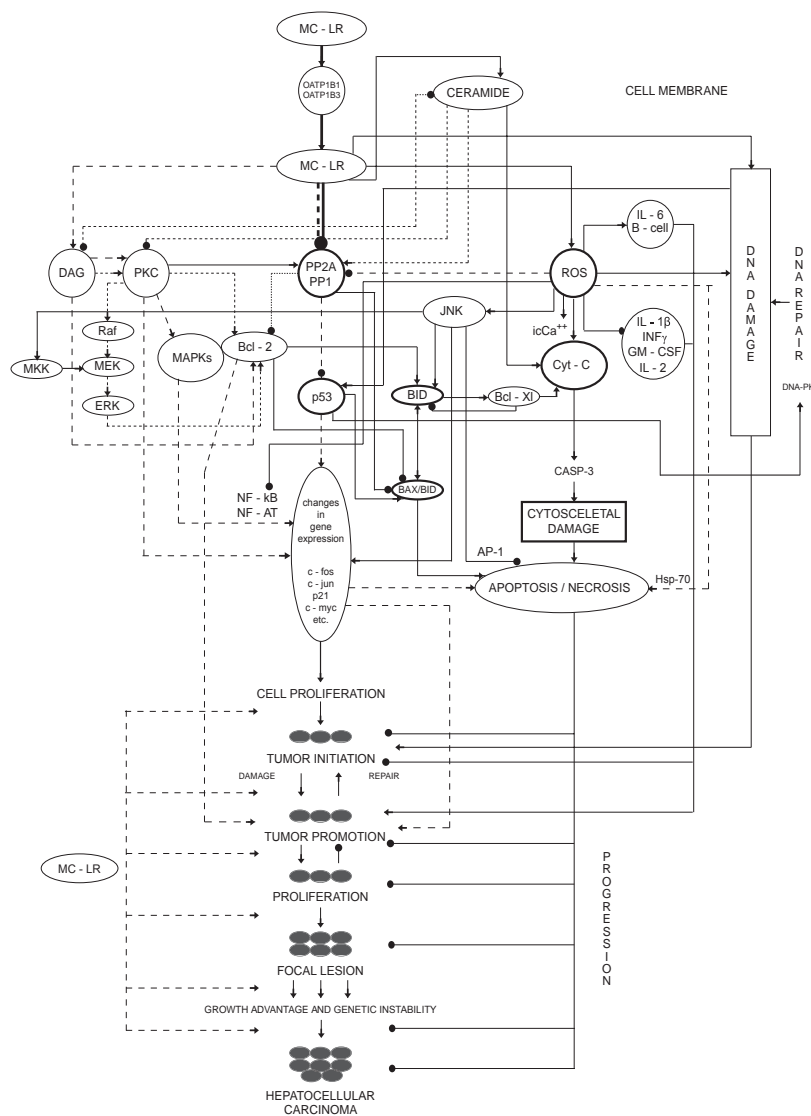

Figure 3. Molecular mechanism at acute and chronic exposure to microcystin LR and induction of hepatocarcinogenesis (1)

## DIFFERENCES IN DISTRIBUTION OF OATP AND EXPRESSION OF SLCO GENE IN MALIGNANT, COMPARED TO HEALTHY TISSUE

### Prostate carcinoma

Testing of frequency and intensity of the gene expression, which encode OATP proteins, SLCO1B1 and SLCO1B3, as well as expression of OATP1B1 and OATP1B3, confirmed that the prostate tumor more usually expresses SLCO1B3 than the healthy tissue. The size of expression increases 45.7 times in tumor, when related to the healthy tissue. The results show the possibility of practical implementation of gene expression measuring in genes, which encode certain proteins or the proteins themselves as potential biomarkers (14).

The studies showed that OATP1B3 transports testosterone. As a result, of the fact that OATP1B3 is multiply expressed in the prostate tissue when compared to the health tissue, it is clear that this transporter has a significant role in biology of prostate carcinoma. Tumor cells, by expression of OATP1B3, independently, actively take over testosterone in order to promote their growth (15).

Expression and genetic variation of OATP affect the result of a hormone-dependant prostate carcinoma treatment, where the time until failure is shortened, i.e. the time to occurrence of tumor resistance to this therapy which inhibits production or effect of androgenic hormones and the occurrence of hormone-independent tumor. In accordance with the knowledge on genetic variation and expression of OATP in prostate carcinoma, therapeutic decisions can be made (14).

### Colon carcinoma

Measuring of expression of SLCO genes, which encode certain carrier proteins and the OATP proteins themselves in colon carcinoma, resulted in a fact that there is an increased expression of OATP1B3 carrier in most of colon adenocarcinomas when compared to the healthy tissue. The OATP1B3 expression is specific, other transporter families are not expressed. Increased expression of OATP1B3 is not related to characteristics of the individual patient. Similar OATP1B3 expression finding is found also in the primary breast carcinoma tissue (14, 16).

The results of OATP1B3 expression analysis in premalignant polyp and polyps of low malignant potential show an increased expression of carriers in a premalignant polyp and no expression in polyps of low malignant potential, which may confirm that OATP1B3 expression is the key element and an early event in colorectal carcinogenesis, which is maintained through tumor progression (16).

As a consequence of excessive OATP1B3 expression in colorectal adenocarcinoma, the tumor becomes resistant to chemotherapy. The resistance is related to and excessive expression of the carriers in tumors with non-mutated p53 tumor suppressor. p53 tumor suppressor is responsible for the programmed cell death, apoptosis, chemotherapy effect, if it is not possible for the damaged DNA to be repaired. An excessive OATP1B3 expression is in correlation with the reduced role of the non-mutated p53 in DNA preservation. The observed resistance of tumor cells to cytostatics is present if there is normal transportation activity of OATP. OATP1B3 is responsible for the irinotecan influx, but it is confirmed that oxaliplatin and other platinum derivatives do not interact with organic anionic transporters (12, 16).

Antiapoptotic activity directed towards chemotherapy is related to excessive expression of OATP1B3 in tumor cells, which interferes the p53 transcriptive activity. Further research on molecular interaction of OATP1B3 and p53 is necessary, as well as testing of the clinical significance of the excessive OATP1B3 expression as potential chemotherapy resistance factor (16).

### Breast carcinoma

An excessive expression of carriers for organic anions is noticed in the study performed by the Japanese experts with the sample of 102 patients, diagnosed with breast carcinoma. The excessive expression of the carrier for estron-3-sulfate is observed in 50% of tested samples, which was related to the growth mechanism of the hormone dependant breast tumor. The reason for such carrier expression in the breast tumor could not be explained. An excessive expression is related to the tumor size, the disease recurrence probability and prognosis. Thus, the study

concluded that organic anion carrier expression could be a significant prognostic factor in breast carcinoma (17).

Furthermore, in the independent study, it was determined that MC-LR, the product of blue-green algae blooms, in low concentrations has estrogen potential, most probably due to indirect interaction with estrogen receptors. It is concluded that in concentrations lower than those present in natural environment, MC-LR may express reproductive toxicity due to estrogenic characteristics (18).

These two studies may lead to a conclusion that MC-LR, which has estrogenic characteristics and is transported by the carrier for organic anions, which are excessively expressed in breast tumors, could affect the development of this kind of disease.

### EXPRESSION AND THE STAGE OF THE DISEASE

Data on SLCO expression may be related both to disease differentiation and its stage. The research results showed an increased frequency of SLCO1B3 expression in prostate carcinoma with the advanced, more aggressive tumor (Gleason score), while in colon cancer, an increased SLCO1B1 expression is in correlation with mild differentiation (14).

### IMPLEMENTATION OF THE MICROCYSTIN ANALOG AS ANTICANCER AGENTS – POSSIBILITY OR MYTH

The microcystin molecule, cyclic heptapeptide, has about 80 variants because of the possibility of amino acid residues to change. This shows a wide spectrum of biological effects, which brought the idea on possible synthesis and implementation of microcystin analogs in therapeutic purposes. Microcystin influx is enabled by the transportation systems for transfer of organic anions OATP1B1 and OATP1B3, which are almost exclusively, distributed in hepatocytes and OATP1A2, which is almost ubiquitous. The studies showed and enhanced presence of these carriers in carcinomas like hepatocellular, colorectal, prostate carcinoma, non-microcellular bronchial carcinoma, breast carcinoma. The relationship between microcystin and toxicity, expressed by protein phosphatase PP1 and PP2A inhibition is confirmed.

Noel et al. study showed that phosphatase inhibition is the goal for development of anticancer agents with microcystin LR structure and the structure of its analogues, where, the toxic activity of MC-LR and its analogues at cells, which contained the carriers OATP1B1 and OATP1B3 was obtained (5).

In the Noel R et al. study, it was shown that cytotoxic concentration is lower than the one, which is toxic for liver, which is very significant because it is necessary to find the therapeutic window for microcystins and analogues. Microcystin is quickly accumulated in liver with 70% of total dosage, which is accumulated 30 minutes after the injection. Cytotoxic activity of microcystin LR is fast within the time frame of 1 hour, and maximal activity is observed after 6 hours. Microcystin cytotoxicity is related to PP2A inhibition (5).

High concentration of microcystin in liver, which is achieved by sublethal doses, shows the different mechanism of microcystin toxicity in healthy hepatocytes and carcinoma cell. The differences in toxicity mechanism imply the possibility that the hepatocytes' death is caused by some intracellular goal other than inhibition of phosphatase enzymes. The goals of microcystin effect in the healthy hepatocyte are aldehyde dehydrogenase

II, an enzyme included in acetaldehyde detoxification and prevention of free oxygen radicals forming and ATP sintase, its  $\beta$  subunit (5).

It is also presumed that the effect of higher doses of microcystin causes cytotoxicity in healthy cells by creation of reactive oxygen radicals, which results in DNA damaging. The third possible reason for the difference in microcystin toxicity in healthy cell is a different effect of phosphatase enzyme inhibition in malignant when compared to a healthy cell. The basis of such a difference is the connection of cytotoxic effect, which occurs by inhibition of phosphatase in a malignant cell, and which depends on activities of specific kinases, whose activity is often changed in the malignant cell. An example for this is phosphatase inhibition by okadaic acid, which results in apoptosis in malignant cells with mutated Ras oncogene (5).

Finally, we must take into consideration the metabolic differences between a healthy and a tumor cell. This fact perhaps creates the basis for implementation of microcystin and analogues in therapeutic purposes in tumor cells, without any effect to healthy cells, which would, possibly, enable selectivity in cytotoxic effect of microcystin. Animal hepatocyte exposure to sublethal concentrations of microcystin LR resulted in acute increase of concentration of intracellular glutathione and occurrence of reactive oxygen radicals. By addition of N-acetylcysteine into the medium of cell culture, increased the concentration of glutathione and reduced the cell sensitivity to microcystin effect, while by addition of buthionine sulfoximine, the effect was the opposite. This confirmed that glutathione plays a significant role in detoxification of high concentrations of microcystin and that glutathione does not have such role when microcystin is applied in lower concentrations in cells expressing OATP, like the cells of hepatocellular carcinoma (5).

The basis for selective effect of lower concentrations of microcystin and its analogues are the differences in toxicity mechanism, which are expressed in the malignant and healthy cell, differences in detoxification, differences in OATP expression in various malignant tissues when compared to non-malignant, normal tissues. A possible synthesis of various variants of microcystin with replacements in amino acidic residues is also significant, because it gives the analogues, which may express greater cytotoxic efficacy (5).

There is a matter of unwanted side effects, which are expressed by the "classic" antineoplastics as non-selective agents. More precisely, in the case of microcystin, the clinical trials are to clarify all unwanted side effects, especially those characteristic for antineoplastics like nausea, vomiting, alopecia, reproductive toxicity, hematological toxicity. Significant unwanted side effects of the "classic" antineoplastics results from their emetogenic potential. Microcystin molecule, which is potentially antineoplastic, could express emetogenic potential because the observed poisoning, besides some other manifestations, implies vomiting. This is confirmed by numerous observations of accidental poisoning. The accidental poisoning was observed in Southern Australia, New Wales and Victoria in people after recreation in water contaminated with cyanobacteria and their toxins. The poisoning symptoms included: diarrhea, vomiting, flu-like symptoms, rash, mouth ulcerations, fever, eye and ear irritation. Similar symptoms were also observed in Poland (19, 20). Microcystins were responsible for the death of the patient caused by the presence of these hepatotoxins in water used in dialysis.

The poisoning symptoms were: vision disorder, nausea, vomiting. The death occurred due to acute liver failure because of practically accidental intravenous injection of microcystin present in the water used for dialysis (21, 22).

## DISCUSSION AND CONCLUSION

A „classic“ chemotherapy is not selective. It stops the growth of malignant cells and introduces them into apoptosis, but it does not affect the basic molecular mechanisms in the cancer cell itself. Furthermore, such chemotherapy does not have the strength to eliminate all malignant cells due to what, the resistance to antineoplastics and development of malignant cell clones often occurs. Only one of the goals in anticancer chemotherapy would be to base the therapy on carcinoma cell biology and to inactivate the components of the signaling pathways (23). The other goal might be a more selective effect, i.e. the effect to a diseased, tumor cell and sparing of the healthy cell. This possibility exists for microcystin molecules and analogues, after confirmation of their cytotoxic activity, and selectivity of their effect would be the consequence of the excessive expression of their carriers in the malignant tissue. Structure, distribution, localization in the cell and the function of OATP in transmission of substrates in the human healthy tissue are well studied. The research was directed towards OATP expression in the malignant tissue and it was determined that there is an excessive expression in colon, breast, colorectal carcinoma. The connection between the tumor advancement and carrier expression was established. Now that the structure of the microcystin molecule, its impact to human health, toxicity mechanisms, possibility of toxicity and selective activity in relation to the tumor cell are all clarified, are we far away from clinical trials on microcystin molecules and analogues in the search for the answers related to implementation of these molecules in the therapy of a malignant disease in humans? Is the potential of the microcystin molecule and the analogue, as the selective anticancer agents, going to be used, is yet to be seen.

## Conflict of interest

We declare no conflicts of interest.

## REFERENCES

- 1 Svircev Z, Baltić V, Gantar M, Juković M, Stojanović D, Baltić M. Molecular Aspects of Microcystin-induced Hepatotoxicity and Hepatocarcinogenesis. *Journal of Environmental Science and Health, Part C*. 2010;28:39-59.
- 2 Svircev Z, Krstić S, Miladinov-Mikov M, Baltić V, Vidović M. Freshwater Cyanobacterial Blooms and Primary Liver Cancer Epidemiological Studies in Serbia. *Journal of Environmental Science and Health, Part C*. 2009;27(1):36-55.
- 3 de la Cruz AA, Antoniou MG, Hiskia A. Can we effectively degrade microcystins?-Implications on human health. *Anticancer Agents Med Chem*. 2011;11(1):19-37.
- 4 Campos A, Vasconcelos V. Molecular Mechanism of microcystin Toxicity in Animal Cells. *Int J Mol Sci*. 2010;11:268-87.
- 5 Monks NR, Liu S, Xu Y, Yu H, Bendelow AS, Moscow JA. Potent cytotoxicity of the phosphatase inhibitor microcystin LR and microcystin analogues in OATP1B1- and OATP1B3-expressing HeLa cells. *Mol Cancer Ther*. 2007;6(2):587-98.
- 6 Klassen CD, Aleksunes LM. Xenobiotic, Bile Acid, and Cholesterol Transporters: Function and Regulation. *Pharmacol Rev*. 2010;62:3-9

- 7 Meier-Abt F, Mokrab Y, Mizuguchi K. Organic Anion Transporting Polypeptides of the OATP/SLCO Superfamily: Identification of New Members in Non mammalian Species, Comparative Modeling and a Potential Transport Mode. *J Membrane Biol.* 2005;208:213-27.
- 8 Meier PJ, Hagenbuch B. The superfamily of organic anion transporting polypeptides. *Biochimica et Biophysica Acta-Biomembranes.* 2003;1609(1):1-18.
- 9 Fischer WJ, Alzheimer S, Cattori V, Meier PJ, Dietrich DR, Hagenbuch B. Organic anion transporting polypeptides expressed in liver and brain mediate uptake of microcystin. *Toxicol Appl Pharmacol.* 2005;203(3):257-63.
- 10 Hagenbuch B, Meier PJ. Organic anion transporting polypeptides of the OATP/SLC21 family: phylogenetic classification as OATP/slco superfamily, new nomenclature and molecular/functional properties. *Pflugers Arch-Eur J Physiol.* 2004;447:653-65.
- 11 Pereira SR, Vasconcelos VM, Antunes A. The phosphoprotein phosphatase family of Ser/Thr phosphatases as principal targets of naturally occurring toxins. *Crit Rev Toxicol.* 2011;41(2):83-110.
- 12 Ilić M. Citotoksični antineoplastici u terapiji malignih bolesti. Beograd: Univerzitet u Beogradu, Farmaceutski fakultet; 2009.
- 13 Takumi S, Komatsu M, Furukawa T, Ikeda R, Sumizawa T, Akenaga H, et al. p53 Plays an important role in cell fate determination after exposure to microcystin-LR. *Toxicol Appl Pharmacol.* 2010;245(1):9-20.
- 14 Pressler H, Sissung TM, Venzon D, Price DK, Figg WD. Expression of OATP Family Members in Hormone-Related Cancers: Potential Markers of Progression. *PLoS One.* 2011;6(5):e20372
- 15 Hamada A, Sissung T, Price DK, Danesi R, Chau CH, Sharifi N, et al. Effect of SLC01B3 Halotype on Testosterone Transport and Clinical Outcome in Caucasian Patients with Androgen-Independent Prostate Cancer. *Clin Cancer Res.* 2008;14:3312-8.
- 16 Lee W, Belkhiri A, Lockhart AC, et al. Overexpression of OATP1B3 Confers Apoptotic Resistance in Colon Cancer. *Cancer Res.* 2008;68:10315-23.
- Muto M, Onogawa T, Suzuki T, Ishida T, Rikiyama T, Katayose Y, et al. Human liver-specific organic anion transporter-2 is a potent prognostic factor for human breast carcinoma. *Cancer Sci.* 2007;98(10):1570-6.
- 17 Oziol L, Bouaicha N. First evidence of estrogenic potential of the cyanobacterial heptotoxins the nodularin-R and the microcystin-LR in cultured mammalian cells. *J Hazard Mater.* 2010;174(1-3):610-5.
- 18 Pilotto LS, Douglas RM, Burch MD, Cameron S, Beers M, Rouch GJ, et al. Health effects of exposure to cyanobacteria (blue-green algae) during recreational water-related activities. *Aust N Z J Public Health.* 1997;21(6):562-6.
- 19 Mankiewicz J, Walter Z, Tarczyńska M. Apoptotic effect of cyanobacterial blooms collected from Polish water reservoirs. *Int J Occup Med Environ Health.* 2000;13(4):335-44.
- 20 Carmichael WW, Azevedo SM, An JS. Human fatalities from cyanobacteria: chemical and biological evidence for cyanotoxins. *Environ Health Perspect.* 2001;109(7):663-8.
- 21 Bischoff K. The toxicology of microcystin-LR: occurrence, toxicokinetics, toxicodynamics, diagnosis and treatment. *Vet Hum Toxicol.* 2001;43(5):294-7.
- 22 Ilić M. Pharmaco-economic Analysis of Antineoplastics at the Oncology Institute of Vojvodina from 2005 to 2008. *Arch Oncol.* 2009;17:78-9.